

Basic specification

- ◇ Frame size : 80mm
- ◇ Voltage input: 24-60Vdc
- ◇ Encoder : 17bit incremental
- ◇ Motor with brake
- ◇ 2.5 – 3 times overload
- ◇ 2 programmable output
- ◇ 4 programmable input
- ◇ RS232 for configuration

Part Number	iSV2-RS8075V48G
Rated Power(W)	750
Rated Torque(Nm)	2.39
Peak Torque(Nm)	7.17
Rated Speed(rpm)	3000
Peak Speed(rpm)	3900
Rated Voltage(Vdc)	48
Weight(kg)	3.19
Inertia(Kg.cm ²)	0.58
Torque(Nm/A)	0.127
Input Voltage(V)	24~60
Continuous Current(Arms)	19
Peak Current(A)	57
Logic Signal Current(mA)	10
Isolation Resistance(MΩ)	100
Protection Level	IP54 for motor IP20 for drive

Modbus Communication

- ◇ Up to 32 axes supported in one network
- ◇ Modbus RTU based on RS485 communication
- ◇ Built-in indexer , Programmable 16-segment position table, positioning/homing/ limit/ quick stop/ JOG... supported

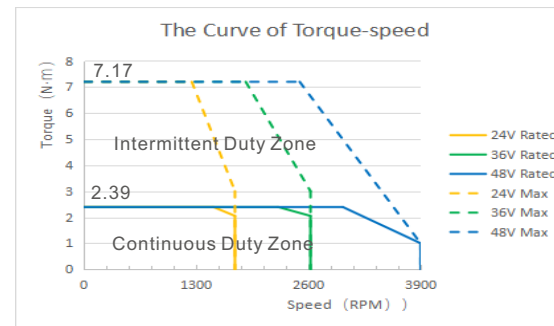
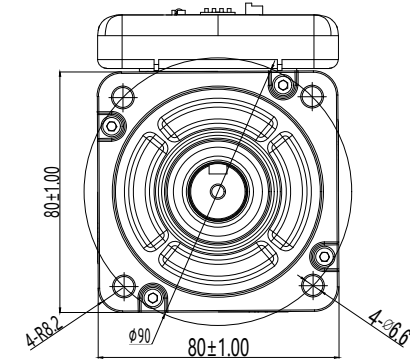
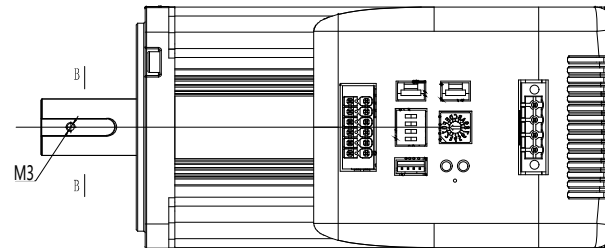
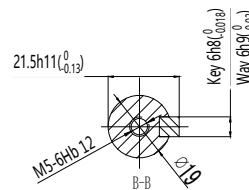
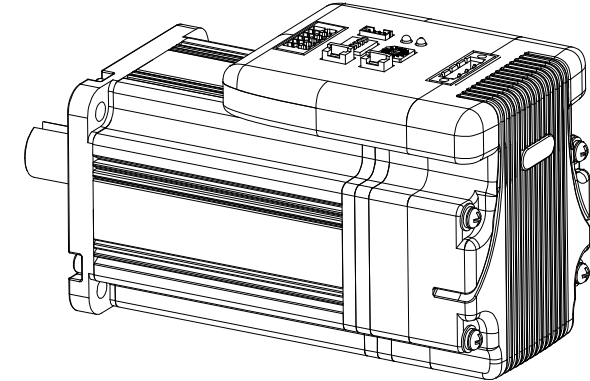
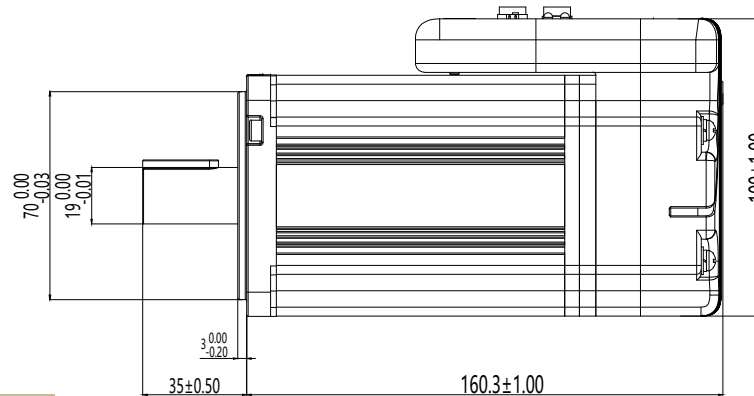

Leadshine Technology Co .Ltd

iSV2-RS8075V48G

Integrated servo motor



48V/750watt/60mm/2.39Nm/With brake