

Basic specification

- ◇ Frame size : 60mm
- ◇ Voltage input: 24-60Vdc
- ◇ Encoder : 17bit incremental
- ◇ Motor with brake
- ◇ 2.5 – 3 times overload
- ◇ 4 programmable input
- ◇ 2 programmable output
- ◇ RS232 for configuration

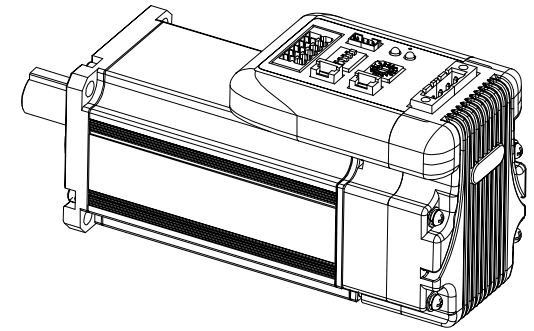

Part Number	iSV2-RS6040V48G
Rated Power(W)	400
Rated Torque(Nm)	1.27
Peak Torque(Nm)	3.81
Rated Speed(rpm)	3000
Peak Speed(rpm)	4000
Rated Voltage(Vdc)	48
Weight(kg)	1.65
Inertia(Kg.cm ²)	0.58
Torque(Nm/A)	0.127
Input Voltage(V)	24~60
Continuous Current(Arms)	10
Peak Current(A)	28
Logic Signal Current(mA)	10
Isolation Resistance(MΩ)	100
Protection Level	IP54 for motor IP20 for drive

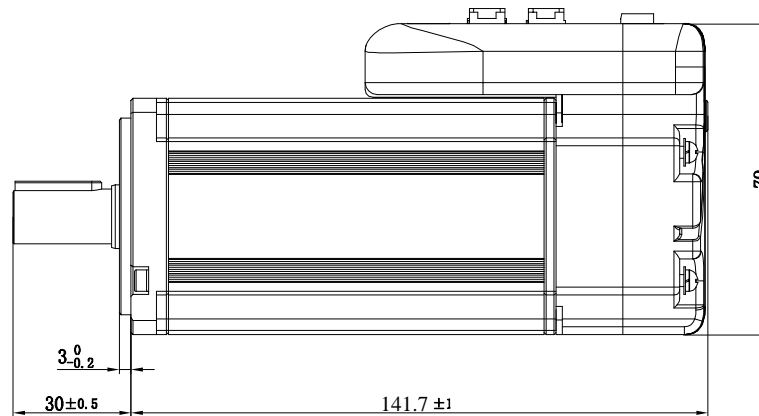
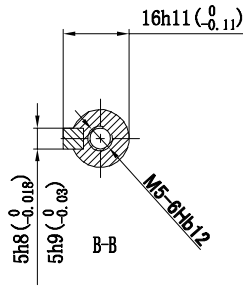
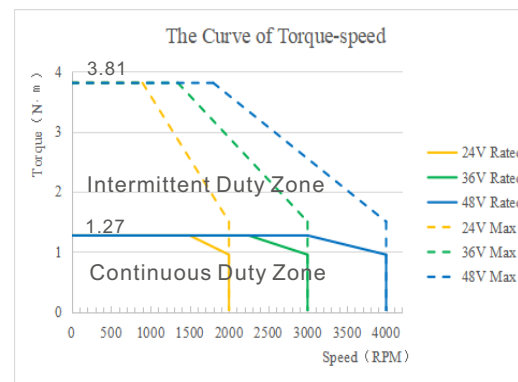
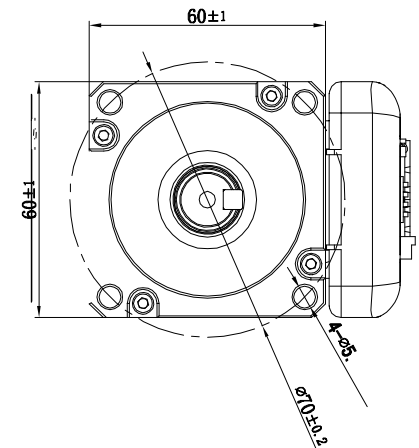
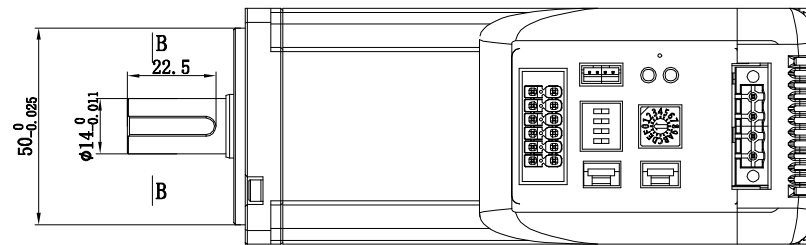

Modbus Communication

- ◇ Up to 32 axes supported in one network
- ◇ Modbus RTU based on RS485 communication
- ◇ Built-in indexer , Programmable 16-segment position table, positioning/homing/ limit/ quick stop/ JOG... supported

Leadshine Technology Co .Ltd

iSV2-RS6040V48G

Integrated servo motor



48V/400watt/60mm/1.27Nm/With brake